

CLASSIC SERIES

AREA LIGHTING | POST TOP, WALL MOUNT

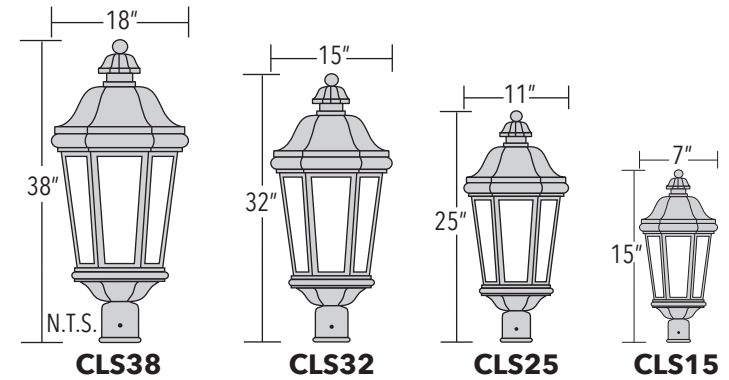

SPECIFICATIONS

LUMINAIRE All aluminum construction.

DRIVER Electronic LED driver, 120-277V
Options: 480V Driver, Dimming control 0-10V.

ELECTRICAL All components UL recognized. Luminaire shipped complete & ready to install.

FINISH Powder coat – Standard colors are Black, White, Dark Green & Dark Bronze. Custom colors available, consult factory. All exposed hardware shall be stainless-steel.

FEATURES + BENEFITS

- Industry leading LED systems
- High efficiency & energy savings
- Environmentally friendly
- Reliable & low-maintenance
- 7-year limited warranty
- UL Listed electrical components
- *Suitable for wet locations*

ORDER INFORMATION EXAMPLE: CLS38-85W-4K-SMT-OF III-PT-BLK-BPC

SERIES	WATTAGE	COLOR TEMP.	VOLTAGE	OPTICS	MOUNTING	FINISH	OPTIONS
CLS15	5W-150W PLEASE SPECIFY	27K 2700K	SMT 120-277V	CL CLEAR LENS	PT POST TOP	BLK BLACK	DIM 0-10V DIMMING
CLS25		3K 3000K	480V	OPL OPAL LENS	WM WALL MOUNT	WHT WHITE	BPC BUTTON PHOTO-CELL
CLS32		35K 3500K		OF OPEN FRAME		GRN DARK GREEN	HSS HOUSE SDE SHIELD
CLS38		4K 4000K		TYPE II		DBZ DARK BRONZE	MS MOTION SENSOR
	5K 5000K	TYPE III		CC CUSTOM COLOR		EMB INTEGRATED EMERGENCY BATTERY	
		CUSTOM COLOR TEMP. CONSULT FACTORY		TYPE IV			*ONLY AVAILABLE ON CLS38
				TYPE V			



ECHO LIGHTING, INC.
Designers and Manufacturers
of Outdoor Lighting

Ph.: +1-323-890-9008
Fax: +1-323-890-1981
Email: info@echoltg.com

5618 E. Washington Blvd.
Commerce, CA 90040
www.echolighting.com