

# LHB SERIES

BOLLARDS | DECORATIVE

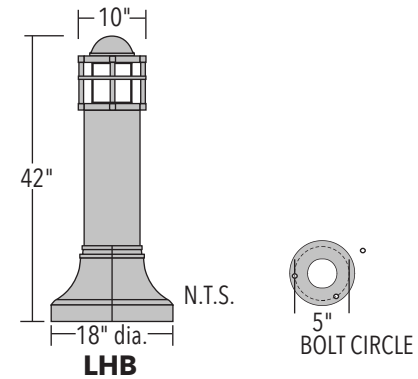
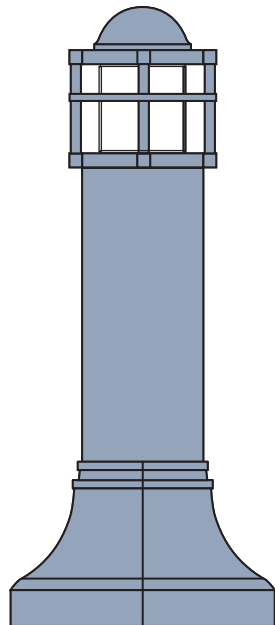

## SPECIFICATIONS

**LUMINAIRE** All aluminum construction.

**DRIVER** Electronic LED driver, 120-277V  
*Options: 480V Driver, Dimming control 0-10V.*

**ELECTRICAL** All components UL recognized. Luminaire shipped complete & ready to install.

**FINISH** Powder coat – Standard colors are Black, White, Dark Green & Dark Bronze. *Custom colors available, consult factory.*  
All exposed hardware shall be stainless-steel.

## FEATURES + BENEFITS

- Industry leading LED systems
- High efficiency & energy savings
- Environmentally friendly
- Reliable & low-maintenance
- 7-year limited warranty
- UL Listed electrical components
- *Suitable for wet locations*

## ORDER INFORMATION EXAMPLE: LHB-20W-4K-SMT-BL V-WHT-DIM

SERIES	WATTAGE	COLOR TEMP.	VOLTAGE	OPTICS	MOUNTING	FINISH	OPTIONS
LHB	5W-50W <small>PLEASE SPECIFY</small>	27K <small>2700K</small> 3K <small>3000K</small> 35K <small>3500K</small> 4K <small>4000K</small> 5K <small>5000K</small> <small>CUSTOM COLOR TEMP. CONSULT FACTORY</small>	SMT <small>120-277V</small> 480V	OPL <small>OPAL LENS</small> TYPE V	N/A	BLK <small>BLACK</small> WHT <small>WHITE</small> GRN <small>DARK GREEN</small> DBZ <small>DARK BRONZE</small> CC <small>CUSTOM COLOR</small>	DIM <small>0-10V DIMMING</small> BPC <small>BUTTON PHOTO-CELL</small> HSS <small>HOUSE SDE SHIELD</small> MS <small>MOTION SENSOR</small> EMB <small>INTEGRATED EMERGENCY BATTERY</small>



**ECHO LIGHTING, INC.**  
*Designers and Manufacturers  
of Outdoor Lighting*

Ph.: +1-323-890-9008  
Fax: +1-323-890-1981  
Email: [info@echoltg.com](mailto:info@echoltg.com)

5618 E. Washington Blvd.  
Commerce, CA 90040  
[www.echolighting.com](http://www.echolighting.com)