

# ARIA SERIES

AREA LIGHTING | POST TOP

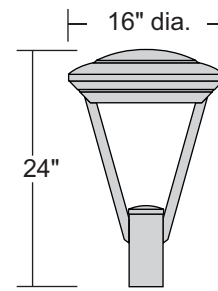

ARIA 16

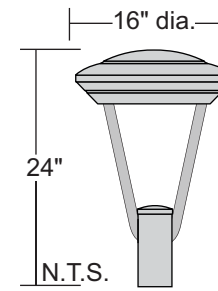

ARIA 216

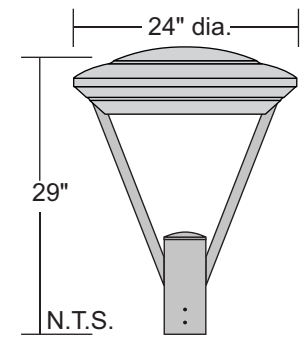

ARIA LG

## SPECIFICATIONS

**LUMINAIRE** All aluminum construction

**DRIVER** Electronic LED driver, 120-277V  
Options: 480V Driver, Dimming control 0-10V.

**ELECTRICAL** All components UL recognized. Luminaire shipped complete & ready to install.

**FINISH** Powder coat – Standard colors are Black, White, Green & Dark Bronze. Custom colors available, consult factory. All exposed hardware shall be stainless-steel.

## FEATURES + BENEFITS

- Industry leading LED systems
- High efficiency & energy savings
- Environmentally friendly
- Reliable & low-maintenance
- 7-year limited warranty
- UL Listed electrical components
- Suitable for wet locations

## ORDER INFORMATION EXAMPLE: ARIA LG-150W-5K-SMT-III-PT-BLK-DIM

SERIES	WATTAGE	COLOR TEMP.	VOLTAGE	OPTICS	MOUNTING	FINISH	OP TIONS
ARIA 16 100W MAX.	5W-200W PLEASE SPECIFY	27K 2700K	SMT 120-277V	TYPE II	PT POST TOP	BLK BLACK	DIM 0-10V DIMMING
ARIA 216 100W MAX.	ARIA 16: 100W MAX ARIA 216: 100W MAX	3K 3000K	480V	TYPE III	PLEASE SPECIFY TENON SIZE OR POLE DIA.	WHT WHITE	BPC BUTTON PHOTO-CELL
ARIA LG		35K 3500K 4K 4000K 5K 5000K CUSTOM COLOR TEMP. CONSULT FACTORY		TYPE IV TYPE V		GRN DARK GREEN DBZ DARK BRONZE CC CUSTOM COLOR	HSS HOUSE-SIDE SHIELD MS MOTION SENSOR EMB INTEGRATED EMERGENCY BATTERY



ECHO LIGHTING, INC.  
Designers and Manufacturers  
of Outdoor Lighting

Ph.: +1-323-890-9008  
Fax: +1-323-890-1981  
Email: info@echoltg.com

5618 E. Washington Blvd.  
Commerce, CA 90040  
www.echolighting.com