

BOSTON SERIES

BOLLARDS | DECORATIVE

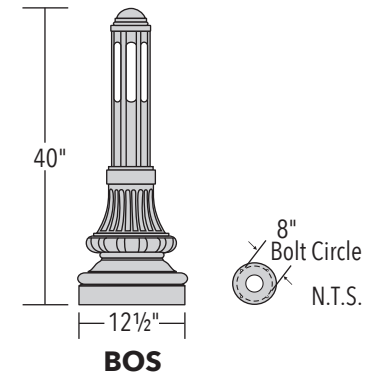

SPECIFICATIONS

LUMINAIRE All aluminum construction.

DRIVER Electronic LED driver, 120-277V
Options: 480V Driver, Dimming control 0-10V.

ELECTRICAL All components UL recognized. Luminaire shipped complete & ready to install.

FINISH Powder coat – Standard colors are Black, White, Dark Green & Dark Bronze. *Custom colors available, consult factory.*
All exposed hardware shall be stainless-steel.

FEATURES + BENEFITS

- Industry leading LED systems
- High efficiency & energy savings
- Environmentally friendly
- Reliable & low-maintenance
- 7-year limited warranty
- UL Listed electrical components
- *Suitable for wet locations*

ORDER INFORMATION EXAMPLE: BOS-15W-4K-SMT-OPL V-GRN-EMB

SERIES	WATTAGE	COLOR TEMP.	VOLTAGE	OPTICS	MOUNTING	FINISH	OPTIONS
BOS	5W-32W <small>PLEASE SPECIFY</small>	27K <small>2700K</small> 3K <small>3000K</small> 35K <small>3500K</small> 4K <small>4000K</small> 5K <small>5000K</small> <small>CUSTOM COLOR TEMP. CONSULT FACTORY</small>	SMT <small>120-277V</small> 480V	OPL <small>OPAL LENS TYPE V</small>	N/A	BLK <small>BLACK</small> WHT <small>WHITE</small> GRN <small>DARK GREEN</small> DBZ <small>DARK BRONZE</small> CC <small>CUSTOM COLOR</small>	DIM <small>0-10V DIMING</small> EMB <small>INTEGRATED EMERGENCY BATTERY</small>



ECHO LIGHTING, INC.
*Designers and Manufacturers
of Outdoor Lighting*

Ph.: +1-323-890-9008
Fax: +1-323-890-1981
Email: info@echoltg.com

5618 E. Washington Blvd.
Commerce, CA 90040
www.echolighting.com