

# GLENMONT SERIES

BOLLARDS | DECORATIVE

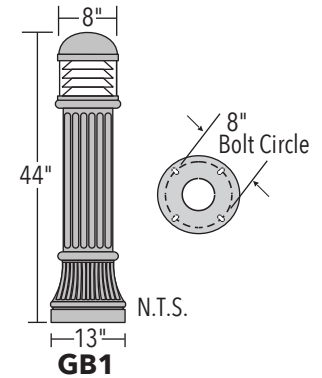
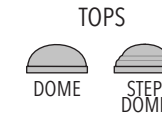
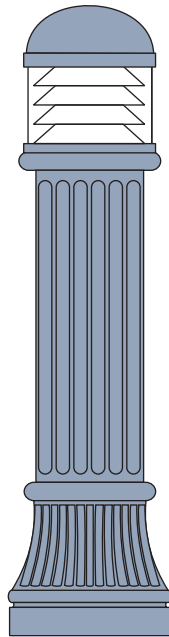

## SPECIFICATIONS

**LUMINAIRE** All aluminum construction.

**DRIVER** Electronic LED driver, 120-277V  
Options: 480V Driver, Dimming control 0-10V.

**ELECTRICAL** All components UL recognized. Luminaire shipped complete & ready to install.

**FINISH** Powder coat – Standard colors are Black, White, Dark Green & Dark Bronze. Custom colors available, consult factory. All exposed hardware shall be stainless-steel.

## FEATURES + BENEFITS

- Industry leading LED systems
- High efficiency & energy savings
- Environmentally friendly
- Reliable & low-maintenance
- 7-year limited warranty
- UL Listed electrical components
- *Suitable for wet locations*

## ORDER INFORMATION EXAMPLE: GMT-24W-35K-SMT-II-DBZ-EMB

SERIES	WATTAGE	COLOR TEMP.	VOLTAGE	OPTICS	MOUNTING	FINISH	OPTIONS
GMT	5W-24W PLEASE SPECIFY	27K 2700K  3K 3000K 35K 3500K 4K 4000K 5K 5000K  CUSTOM COLOR TEMP. CONSULT FACTORY	SMT 120-277V  480V	TYPE II TYPE III TYPE IV TYPE V	N/A	BLK BLACK  WHT WHITE  GRN DARK GREEN  DBZ DARK BRONZE  CC CUSTOM COLOR	DIM 0-10V DIMING  EMB INTEGRATED EMERGENCY BATTERY



**ECHO LIGHTING, INC.**  
Designers and Manufacturers  
of Outdoor Lighting

Ph.: +1-323-890-9008  
Fax: +1-323-890-1981  
Email: info@echoltg.com

5618 E. Washington Blvd.  
Commerce, CA 90040  
www.echolighting.com