

ROUND SERIES

BOLLARDS | STANDARD

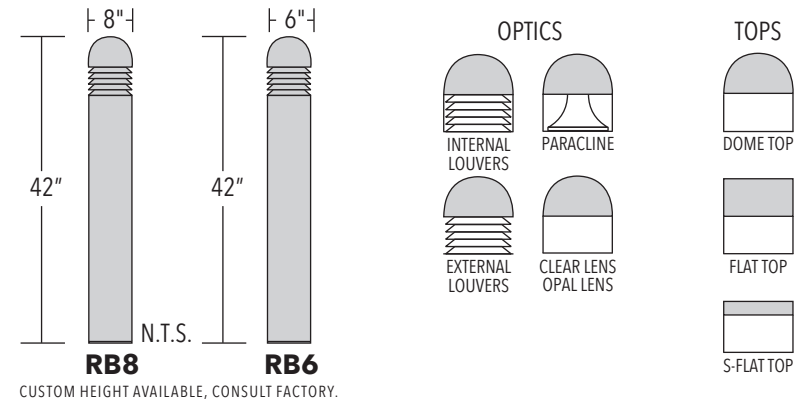

SPECIFICATIONS

- LUMINAIRE** All aluminum construction.
- DRIVER** Electronic LED driver, 120-277V
Options: 480V Driver, Dimming control 0-10V.
- ELECTRICAL** All components UL recognized. Luminaire shipped complete & ready to install.
- FINISH** Powder coat – Standard colors are Black, White, Dark Green & Dark Bronze. *Custom colors available, consult factory.* All exposed hardware shall be stainless-steel.

FEATURES + BENEFITS

- Industry leading LED systems
- High efficiency & energy savings
- Environmentally friendly
- Reliable & low-maintenance
- 7-year limited warranty
- UL Listed electrical components
- *Suitable for wet locations*

ORDER INFORMATION EXAMPLE: RB8-25W-35K-SMT-EL V-DT-DBZ

SERIES	WATTAGE	COLOR TEMP.	VOLTAGE	OPTICS	TOPS	FINISH	OPTIONS
RB6 RB8	5W-32W PLEASE SPECIFY	27K 2700K 3K 3000K 35K 3500K 4K 4000K 5K 5000K CUSTOM COLOR TEMP. CONSULT FACTORY	SMT 120-277V 480V	PA PARACLINE IL INTERNAL LOUVERS EL EXTERNAL LOUVERS CL CLEAR LENS OPL OPAL LENS TYPE V	DT DOME TOP FT FLAT TOP SFT SHORT FLAT TOP	BLK BLACK WHT WHITE GRN DARK GREEN DBZ DARK BRONZE CC CUSTOM COLOR	DIM 0-10V DIMING EMB INTEGRATED EMERGENCY BATTERY



ECHO LIGHTING, INC.
Designers and Manufacturers
of Outdoor Lighting

Ph.: +1-323-890-9008
Fax: +1-323-890-1981
Email: info@echoltg.com

5618 E. Washington Blvd.
Commerce, CA 90040
www.echolighting.com