

SATELLITE 2 SERIES

AREA LIGHTING | POST TOP, WALL MOUNT

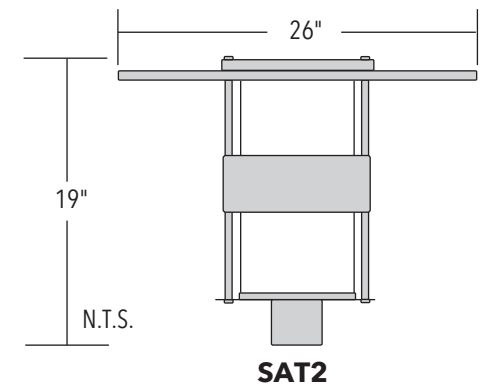

SPECIFICATIONS

LUMINAIRE All aluminum construction.

DRIVER Electronic LED driver, 120-277V
Options: 480V Driver, Dimming control 0-10V.

ELECTRICAL All components UL recognized. Luminaire shipped complete & ready to install.

FINISH Powder coat – Standard colors are Black, White, Dark Green & Dark Bronze. *Custom colors available, consult factory.*
All exposed hardware shall be stainless-steel.

FEATURES + BENEFITS

- Industry leading LED systems
- High efficiency & energy savings
- Environmentally friendly
- Reliable & low-maintenance
- 7-year limited warranty
- UL Listed electrical components
- *Suitable for wet locations*

ORDER INFORMATION EXAMPLE: SAT2-50W-35K-SMT-CL III-PT-WHT-BPC

SERIES	WATTAGE	COLOR TEMP.	VOLTAGE	OPTICS	MOUNTING	FINISH	OPTIONS
SAT2	5W 8W 10W 12W 16W 24W	27K 2700K 3K 3000K 35K 3500K 4K 4000K 5K 5000K CUSTOM COLOR TEMP. CONSULT FACTORY	SMT 120-277V	CL CLEAR LENS OPL OPAL LENS TYPE V	PT POST TOP WM WALL MOUNT	BLK BLACK WHT WHITE GRN DARK GREEN DBZ DARK BRONZE CC CUSTOM COLOR	DIM 0-10V DIMING



ECHO LIGHTING, INC.
*Designers and Manufacturers
of Outdoor Lighting*

Ph.: +1-323-890-9008
Fax: +1-323-890-1981
Email: info@echoltg.com

5618 E. Washington Blvd.
Commerce, CA 90040
www.echolighting.com