

# SPECTRUM SERIES

AREA LIGHTING | PENDANT MOUNT

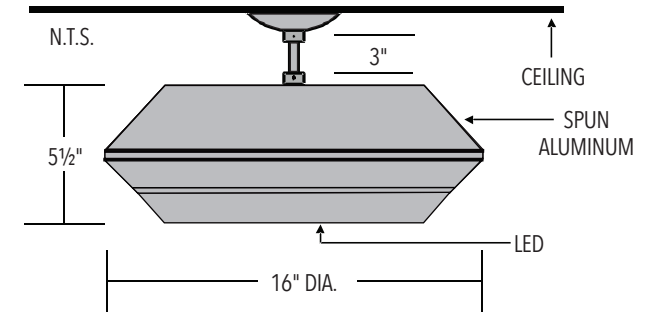
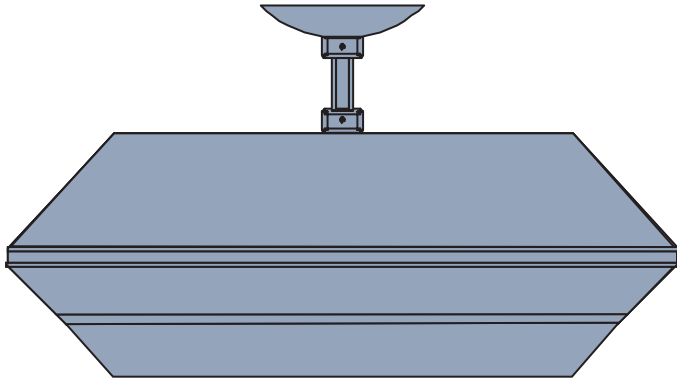

NTN

## SPECIFICATIONS

**LUMINAIRE** All aluminum construction.

**DRIVER** Electronic LED driver, 120-277V  
Options: 480V Driver, Dimming control 0-10V.

**ELECTRICAL** All components UL recognized. Luminaire shipped complete & ready to install.

**FINISH** Powder coat – Standard colors are Black, White, Dark Green & Dark Bronze. Custom colors available, consult factory. All exposed hardware shall be stainless-steel.

## FEATURES + BENEFITS

- Industry leading LED systems
- High efficiency & energy savings
- Environmentally friendly
- Reliable & low-maintenance
- 7-year limited warranty
- UL Listed electrical components
- *Suitable for wet locations*

## ORDER INFORMATION EXAMPLE: NTN-80W-3K-SMT-FL III-PM-CC-EMB

SERIES	WATTAGE	COLOR TEMP.	VOLTAGE	OPTICS	MOUNTING	FINISH	OPTIONS
NTN	5W-95W PLEASE SPECIFY	27K 2700K 3K 3000K 35K 3500K 4K 4000K 5K 5000K CUSTOM COLOR TEMP. CONSULT FACTORY	SMT 120-277V 480V	FL FLAT LENS TYPE II TYPE III TYPE IV TYPE V	PM PENDANT MOUNT PLEASE SPECIFY STEM LENGTH	BLK BLACK WHT WHITE GRN DARK GREEN DBZ DARK BRONZE CC CUSTOM COLOR	DIM 0-10V DIMMING MS MOTION SENSOR EMB INTEGRATED EMERGENCY BATTERY



**ECHO LIGHTING, INC.**  
Designers and Manufacturers  
of Outdoor Lighting

Ph.: +1-323-890-9008  
Fax: +1-323-890-1981  
Email: info@echoltg.com

5618 E. Washington Blvd.  
Commerce, CA 90040  
www.echolighting.com